

Digital SENSOR

CTZN : INDUCTIVE CONDUCTIVITY

Inductive conductivity no sensitive to the fouling

- Sensor regulated in temperature
- Ranges 0 to 100 mS/cm
- Numerical communication **Modbus** RS-485 and SDI12
- Compact, **robust** and watertight

Paramètres mesurés :

- Conductivity compensated in temperature (mS/cm)
- Conductivity non-compensated in temperature (mS/cm)
- Salinity (g/Kg)
- Temperature (°C)

Applications :

- Urban wastewater treatment
- Industrial effluent treatment
- Surface water monitoring
- Sea water
- Fish farming

Inductive method :

A ring-type coil is excited at fixed intervals and the response is retrieved on a second coil, which is linked to the excited coil. The connectivity between the coils (determined by the degree of conductivity) takes place via the conducting solution.

Economic and successful technology that requiring not enough maintenance and not consumable.

Digital Technology :

The “smart” Digital CTZN sensor stores calibration and history data within the sensor. This allows you a “plug and play” system without re-calibration.

Thanks to the Universal Modbus RS485 protocol, the PONSEL Digital CTZN can be connected to all devices commonly used (Datalogger, Controller, Automat, Remote System...).



CTZN Specifications :

Measures									
Measure principle	Inductive conductivity sensor regulated in temperature								
Measure ranges conductivity	0,0 –100,0 mS/cm								
Resolution	0,1								
Measure ranges salinity	5-60 g/Kg								
Working temperature	0 to 50 °C								
Temperature compensation	With NTC or external measure								
Accuracy T°C	± 0.1 °C range 0-40 °C								
Response time	90% of the value in less than 30 seconds								
Stocking temperature	-10°C à + 60°C								
Signal interface	Modbus RS-485 en standard et SDI-12								
Maximum refreshing time	Maximum < 1 seconde								
Sensor power-supply	5 to 28 volts, max 30 V								
Electric consumption	Automatic Standby < 50 µA , Heating time 100 mS								
	Average Modbus RS485/ Range 0-100 mS/cm								
	<table border="1"> <thead> <tr> <th></th> <th>Vin 5V</th> <th>Vin 12 V</th> <th>Vin 24 V</th> </tr> </thead> <tbody> <tr> <td>1 measure/s</td> <td>31 mA</td> <td>15,5 mA</td> <td>11,5 mA</td> </tr> </tbody> </table>		Vin 5V	Vin 12 V	Vin 24 V	1 measure/s	31 mA	15,5 mA	11,5 mA
		Vin 5V	Vin 12 V	Vin 24 V					
1 measure/s	31 mA	15,5 mA	11,5 mA						
Max curent pulse 700 mA during 2 mS, 350 mA during 150 mS									

Sensor	
Dimensions	Diameter max. 62,4 mm, Lenght : 196 mm
Weight	700 g
Material	EPDM, PVC, Stainless steel
Maximum pressure	5 bars
Connexion	9 armoured connectors, polyurethane jacket, bare-wires or waterproof Fisher connector
Protection	IP68

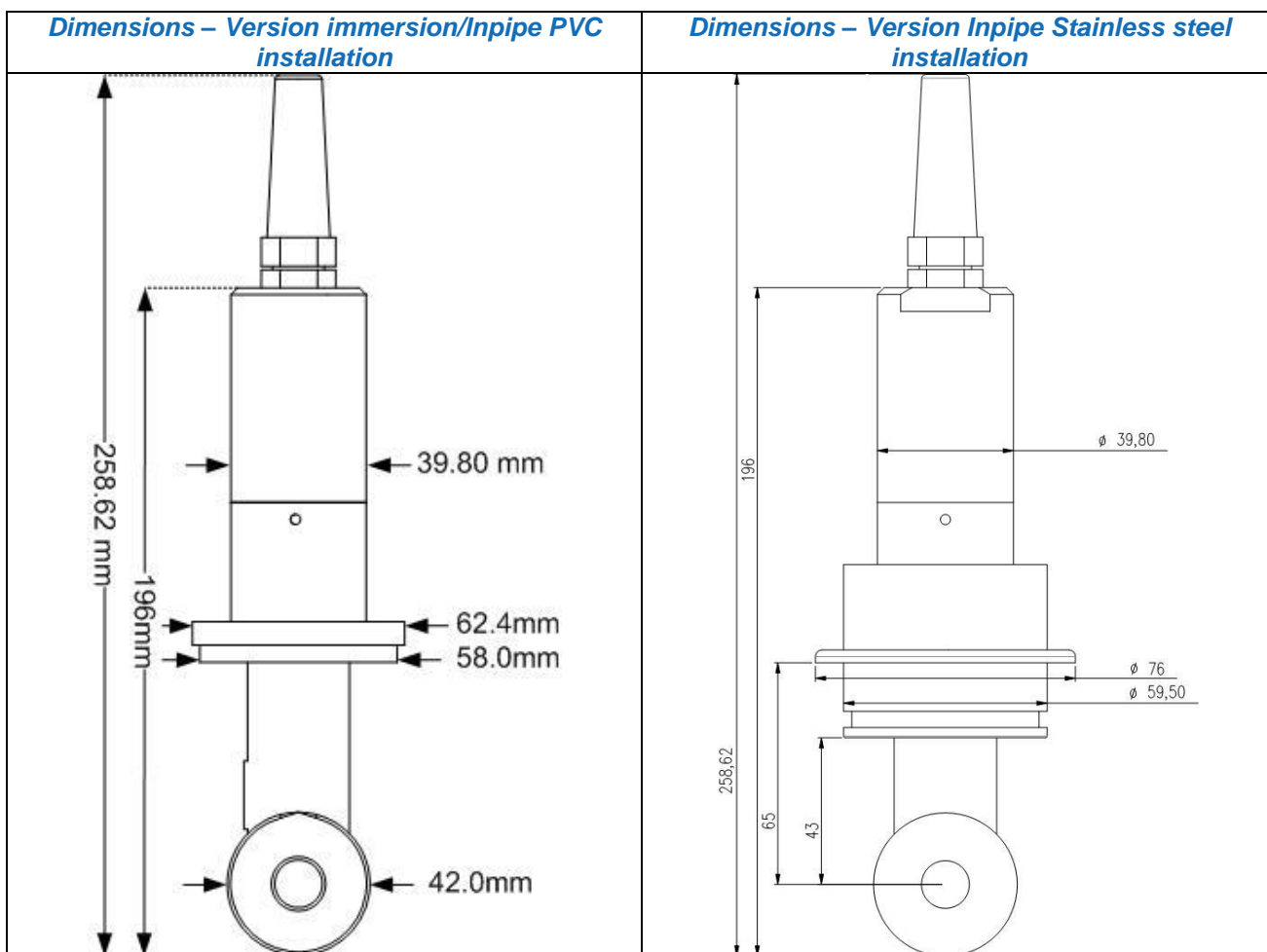

Wiring diagram

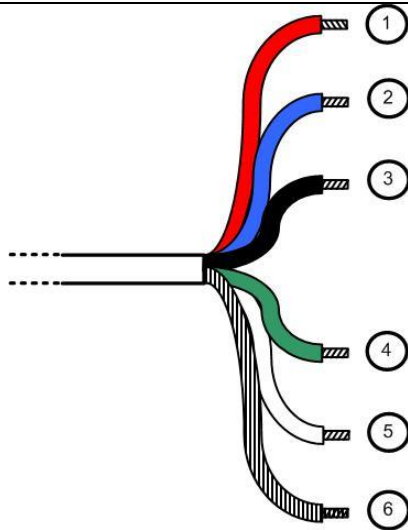

Until 15 meters

Red Purple Yellow Orange pink	Power supply V+
2 - Blue	SDI-12
3 - Black	Power supply V-
6 – Green/Yellow	Cable shield combine
4 - Green	B " RS-485 "
5 - White	A " RS-485 "

Cable length up to 15m

1- Red	Power supply V+
2 - Blue	SDI-12
3 - Black	Power supply V-
4 - Green	B " RS-485 "
5 - White	A " RS-485 "
6 – Green/yellow	Cable shield